

ferrum

**PROVEN CONTINUITY
PUSHER CENTRIFUGES**



+ SWISSMADE

+ Ferrum Ltd.
Centrifuge Technology
Industriestrasse 11
CH-5503 Schafisheim
Switzerland

T +41 62 889 14 11
F +41 62 889 15 13
centrifuges@ferrum.net
www.ferrum.net

+ Ferrum Inc.
Centrifuge Technology
16225 Park Ten Place
Suite 500
Houston, TX 77084
USA

T +1 877 933 3778
F +1 877 711 2329
sales@ferrumUS.com
www.ferrumUS.com

**+ Ferrum Technologies
India Private Ltd.**
105, Shree Saiishwati Co-op. Hsg. Soc.
Mogul Lane
400016 Mahim, Mumbai
India

T +91 222 431 4299
F +91 222 432 2276
sale@ferrumIN.com
www.ferrum.net

**+ Ferrum Canning and Centrifuge
Technology (Kunshan) Co., Ltd.**
No. 329, Jujin Road
Zhangpu Township
215321 Kunshan City
Jiangsu Province
P.R. China

T +86 512 3662 5104
F +86 512 3662 5100
centrifuge@ferrumChina.com
www.ferrumChina.com

APPLICATIONS⁺ SPECIFIC DESIGNS

CHEMICAL INDUSTRY

Chlorides | Sodium chloride | Sea - Lake - Evaporator salt | Potassium chloride | Ammonium chloride

Sulphates | Sodium sulphate anhydride | Sodium sulphate decahydrate | Potassium sulphate | Magnesium sulphate | Ammonium sulphate | Iron sulphate heptahydrate

Chlorates | Sodium chlorate | Potassium chlorate

Nitrates | Sodium nitrate | Potassium nitrate | Lysine

Urea | Different processes

Intermediate Products | Sodium bicarbonate crude | Sodium carbonate monohydrate | PAP P-aminophenole

Fibrous Products | Nitrocellulose Chips - Fibres

Various | Calcium tartrate



MINERAL PROCESSING

Mining | Rock phosphate | Rock salt (NaCl), Sea Salt | Potassium chloride from Flotation

PETROCHEMICAL INDUSTRY

Basic Products | Adipic acid | Bisphenol A | Caprolactam | Paraxylene | ABS, MBS | Polyethylene | PP



CUSTOMISED SOLUTIONS

Ferrum supplies innovative customised and special designs for a very wide range of applications and processes:

- + Product inlet and product distribution systems
- + Solids and filtrate discharge systems
- + Gas-tight designs
- + Explosion-proof designs (according to Directive 94/9/EC)
- + Heated, insulated centrifuge housings
- + Special protection against wear from abrasive products

+ PUSHER CENTRIFUGE PM-23



MECHANICAL DESIGN

Based on the very successful Sulzer-Escher Wyss design, Ferrum has consistently developed the pusher centrifuge further, always in accordance with the latest requirements.

The simple, robust construction is very easy to maintain and permits straightforward commissioning as well as reliable, high performance continuous operation.

The rotary drive and pusher drive for the baskets are powered by two separate electric motors with stepped v-belt pulleys. The rotation of the pusher motor is converted into the pusher movement via a gearbox with an excenter wheel.

DESIGN FEATURES

- + Simple, robust design, high reliability
- + High throughputs under the toughest conditions
- + Purely mechanical pusher drive without hydraulic system
- + Optimally designed inlet section for gentle acceleration of the product
- + Adjustable wash nozzles for optimum cake washing
- + Rinsing connections for easy cleaning of the centrifuge process area
- + Various discharge systems for gentle discharge of the solids
- + Various peripheral components available for the basic model
- + Special designs on request (gas-tight, explosion protection, etc.)



Drive and control unit PM-23

PUSHER CENTRIFUGE⁺

TYPE P-32 TO P-120

MODEL RANGE P-32 TO P-50

The centrifuge types P-32 to P-50 are a new development by Ferrum. Thanks to their high-performance hydraulics, the machines feature compact dimensions and can be operated with a small hydraulic oil volume.

The pusher mechanism is actuated hydraulically, reversal is effected via an external hydraulic control unit. The stroke frequency can be adjusted whilst the stroke length remains constant. The oil pump and the rotor are actuated using two separate electric motors.



MODEL RANGE P-60 TO P-120

Based on the very successful Sulzer-Escher Wyss design, Ferrum has consistently further developed the centrifuge types P-60 to P-120, in accordance with the latest requirements.

The pusher mechanism is actuated hydraulically, reversal is effected via a fully internal reversal unit. The stroke frequency can be adjusted whilst the stroke length remains constant. The oil pump and the rotor are actuated using two separate electric motors.



DESIGN FEATURES

- + Compact, robust and reliable design
- + Operation with a small hydraulic oil volume
- + High throughputs under the toughest conditions
- + Hydraulic pusher drive for high pusher forces
- + Optimally designed inlet section for gentle acceleration of the product
- + Adjustable wash nozzles for optimum cake washing
- + Rinsing connections for easy cleaning of the centrifuge process area
- + Various discharge systems for gentle solid discharge
- + Various peripheral components available for the basic model
- + Special designs on request (gas-tight, explosion protection, etc.)

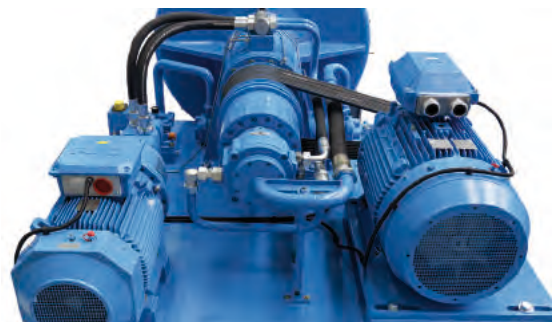

Drive and control unit P-100

+ DOSING DEVICES AND AGITATORS TROUBLE-FREE FEED



DOSING DEVICES (DAU)

The dosing devices with integrated agitators designed by Ferrum are installed at the discharge opening of the static thickening tank. Depending on the model, a maximum of four outlets can be realised per dosing device to permit simultaneous feeds of up to four centrifuges.

The integrated dosing valves can be actuated manually, electrically or pneumatically to control the suspension feed rate to each centrifuge.

An agitator integrated into the dosing device prevents solids de-posits as well as blockages in the suspension outlets. Agitators and dosing valves are cleaned with liquid via flush connections. Connection to the customer's or Ferrum's control system permits optimally matched control of the devices.



AGITATORS (RW)

The agitator has a similar layout to the dosing device, however it is not equipped with integrated dosing valves. Suitable standard dosing valves can be fitted to the suspension outlets and controlled by the customer's or Ferrum's control system.

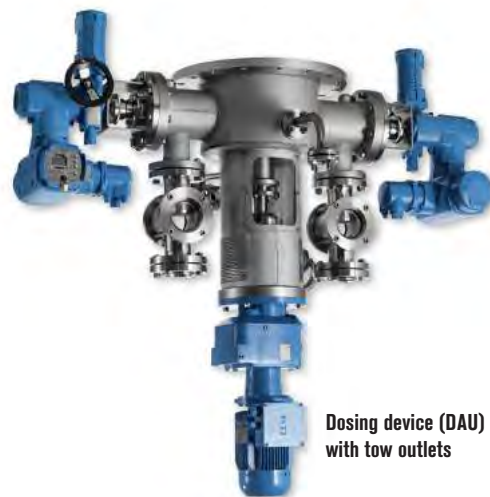

Dosing device (DAU)
with two outlets

EXEMPLARY EFFICIENCY⁺

PRINCIPLE OF OPERATION

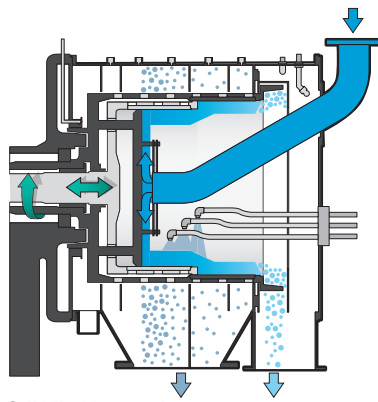

Solid-liquid separation

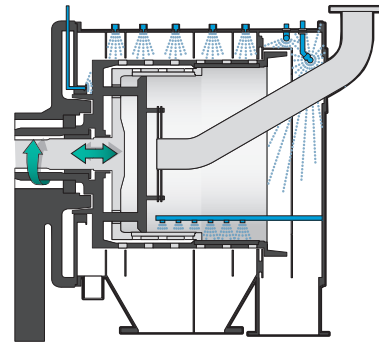

Rinsing the process area

Pusher centrifuges are continuously operating filter centrifuges and can have several basket stages depending on the application. The solid-liquid separation shown here demonstrates a two-stage pusher centrifuge. Periodic rinsing of the process area is achieved by means of integrated rinsing nozzles and pipes.

SOLID-LIQUID SEPARATION

Suspension inlet | The centrifuge is continuously fed with the suspension to be separated (solid-liquid mixture) via the inlet pipe. In case of poor flow characteristics, the feed is effected via an inlet screw conveyor (not shown).

Suspension distributor | The distributor accelerates and distributes the suspension over the entire periphery of the sieves in the filling area of the first basket stage. Ferrum offers various application-specific distribution systems for even and gentle acceleration and distribution of the suspension.

First basket stage | The greatest part (approx. 80%) of the liquid is already filtered out in the feed zone of the first basket stage, where a stable cake forms. The first basket stage performs, along with a rotational, also an axial pusher movement (oscillation movement).

Second basket stage | The cake is pushed in annular sections by each pusher movement from the first to the second basket stage.

Solids discharge | After the second basket stage, the solids leave the centrifuge via the discharge channel and the solids housing. Depending on the application, different discharge systems are used.

Product washing | If necessary, impurities in the mother liquor are washed out. The wash liquid is applied continuously over the cake via several adjustable wash nozzles.

Filtrate housing | The filtrate (filtered mother liquor and wash liquid) is collected in the filtrate housing and drawn off. Depending on the application, different filtrate housings and filtrate cyclones are used.

Filtrate separation | If necessary, the filtrate can be drawn off separately in each filtrate zone by means of separation plates fitted in the filtrate housing and disposed of or reused (e.g. counterflow washing).

RINSING THE PROCESS AREA

The centrifuge process area is cleaned using rinsing liquid supplied through optimally arranged cleaning nozzles and a cleaning pipe. Periodic rinsing prevents the crystal formation in the sieves and deposits in the solids housing.

+ PRE-THICKENING AN IMPORTANT PROCESS STEP

As a continuously operating machine, the pusher centrifuge requires process conditions and solids concentrations as constant as possible to ensure optimum operation and consistent product quality.

For process and plant-related reasons, the necessary feed conditions are often not achieved. As a solution for this problem, Ferrum offers various pre-thickening systems and dosing devices.

Depending on requirements, Ferrum supplies the design, production and automation of the related system.

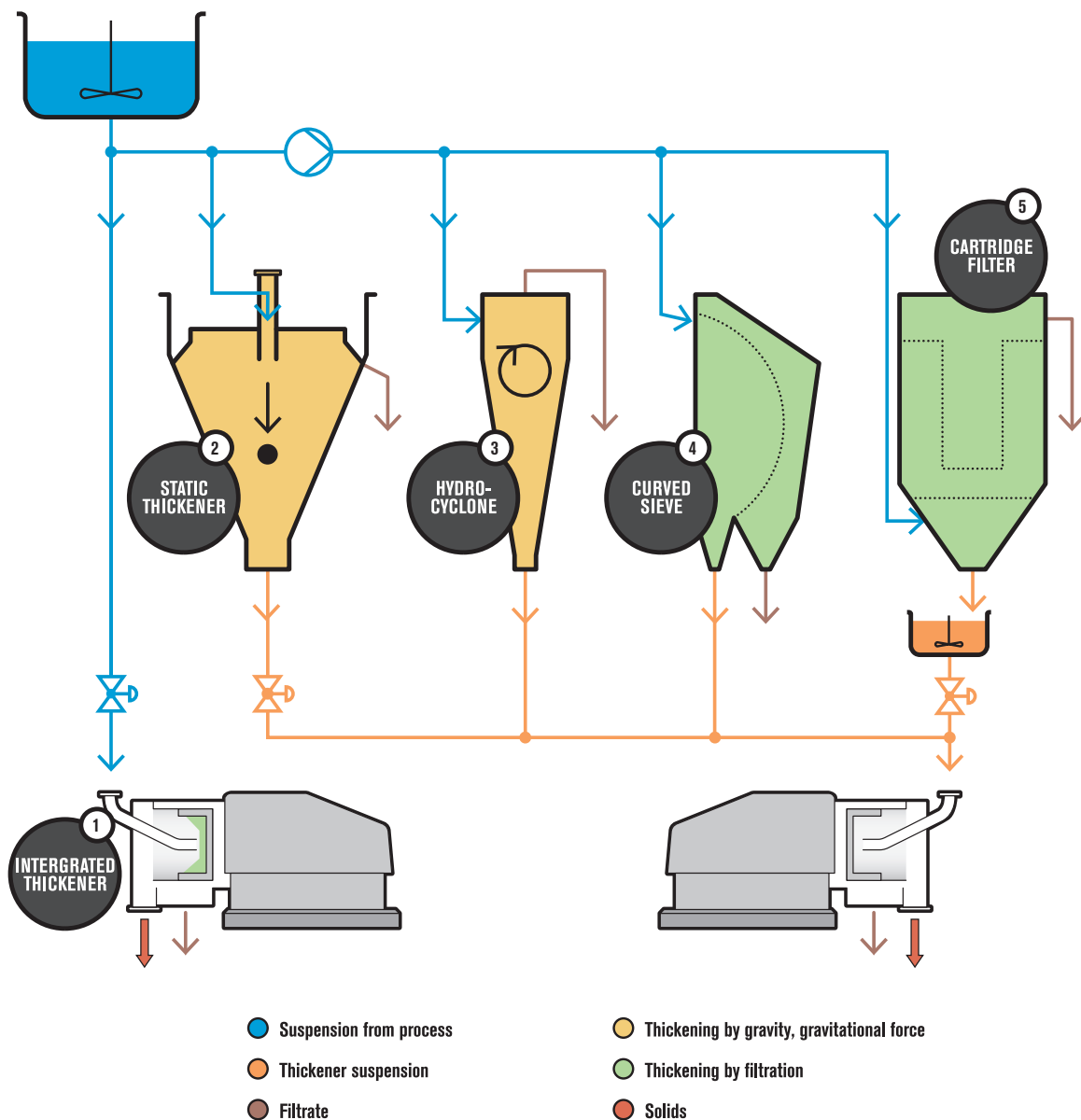



1. INTEGRATED THICKENER – A FERRUM INNOVATION

The integrated thickening cone for pusher centrifuges was developed and patented by Ferrum. Depending on the application separate external pre-thickening is not required. Fluctuating feed concentrations are compensated, cake formation is improved and the product is accelerated more gently. Today for certain applications the integrated thickening cone is our standard.



2. STATIC THICKENER

The static thickener is used if the sedimentation characteristics of the solids and the space available permit. The thickened suspension can be supplied to several centrifuges at the same time via the Ferrum dosing device.



3. HYDROCYCLONE

Solids and liquid are separated by centrifugal acceleration. The thickened suspension in the outlet at the base is fed to the centrifuge. To use a hydrocyclone the density of the solids must be higher than that of the mother liquor (as with the static thickener).



4. CURVED SIEVE

The suspension is fed onto the curved sieve surface under pressure. During this process a part of the liquid is separated through the sieve slots. The thickened suspension is collected at the end of the sieve and fed to the centrifuge.

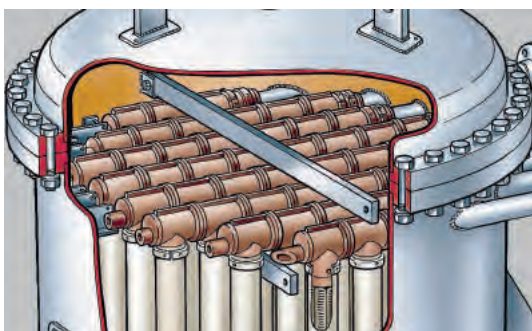

5. CARTRIDGE FILTER

Pre-thickening is achieved by the pressure difference at the cartridge filters (normally by overpressure) which are in a closed vessel. Cartridge filters operate discontinuously. To achieve a continuous process, the thickened suspension is collected in a collection tank before feeding the centrifuges.

+ AUTOMATION SYSTEMS RELIABLE CONTROL

Automation of centrifuges is of central importance to Ferrum. Ferrum has invested many years into the development of centrifuge automation systems. Proven, standardised hardware and software modules are used as a basis and are supplemented with customer specific elements.

OVERVIEW OF THE RANGE OF CONTROL SYSTEMS AND DRIVES

- + Safety analyses, safety circuits
- + Automation of the process, software programming
- + Design and installation of cabinets for control systems and drives, as well as operator panels
- + Connection to distributed control systems, remote maintenance
- + Explosion protection up to Ex zone 1 (according to Directive 94/9/EC)
- + Documentation: diagrams, concept descriptions, operating instructions, safety certificates, etc.
- + Commissioning of complete systems on-site



DRIVE SYSTEMS AND SAFETY CONTROL SYSTEMS

Our drive systems and safety control systems guarantee safe and optimised operation of the centrifuge. The systems are state of the art. They are continuously developed and adapted to our risk analyses as well as to the latest directives and standards.

Frequency converters of the latest generation with integrated safety functions are used to control the speed.

CONTROL SYSTEMS AND TERMINALS TO FACILITATE EASE OF USE

Control and visualisation software permits easy operation and control of the solid-liquid separation process. Thanks to our extensive range of different control systems, operator panels and components from leading suppliers, we efficiently implement comprehensive customer requirements.

Ferrum can supply simple operator panels on which the basic functions are controlled manually using pushbuttons, to fully automated PLC systems with visualisation for large systems.



Operator panel with visualisation



Operator panel with push button

EXPERIENCE⁺ FERRUM INNOVATION

PULSED FEEDING

Application | «Flooding» is a problem that often occurs during the operation of pusher centrifuges. In this situation, the pusher centrifuge does not adequately remove the liquid from the suspension. A suspension channel forms that propagates axially over the product cake and can even reach the solids discharge.

The consequences are unbalance, increased residual moisture content and impurity of the solids. A possible solution is to change the process parameters, to influence the characteristics of the suspension in the upstream area such that flooding no longer occurs at the required solids throughput. If this option is not possible, the only way to prevent flooding is to reduce the throughput.

- + Higher throughput without flooding (product-dependent, up to a factor of 2)
- + Switch between pulsed and continuous feed without process interruption
- + Easy upgrade of existing units

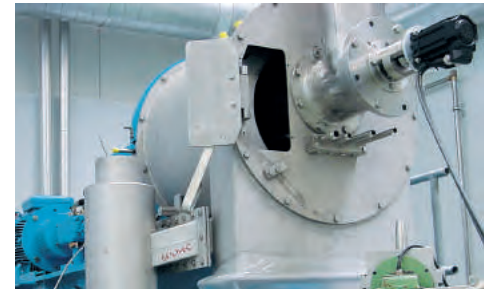

PULSED WASHING

Conventional washing | Continuous jet of wash liquid sprayed onto product

Pulsed washing | Discontinuous (pulsed) jet of wash liquid sprayed onto product

- + Higher product purity
- + Lower wash liquid consumption
- + Lower solubility losses
- + Lower energy consumption

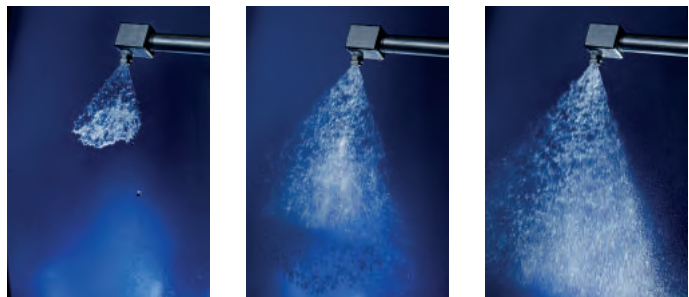

WORLDWIDE



1 BRAND – 4 BUSINESS UNITS



CANNING TECHNOLOGY



CENTRIFUGE TECHNOLOGY



MANUFACTURING



FOUNDRY